



Application

- Car wash
- Repair and maintenance
- Body work

Approvals

- Renault
- Volkswagen Group



Sololift 1.35 Sa

Electro-hydraulic single-ram lift, 3.5 t capacity, superstructure with arms

Description:

Steel cassette:

- Waterproof steel cassette
- Self-carrying

Hydraulic unit:

- Hard-chrome plated cylinder
- Integrated anti-rotation device
- Corrosion-free guiding elements
- Hydraulic unit with immersed motor for fitting in floor
- Ecological hydraulic fluid
- Pneumatic emergency lowering
- Pushbutton control unit

Superstructure:

- Single telescopic arms
- Internal arm locking system
- Low minimum height

Standard colours

- Base plate: Grey RAL 7016
- Arms: Red RAL 3020

Technical data	
Lifting capacity	3,500 kg
Lifting height	1,780 mm
Working height	1,920 - 1,980 mm
Cylinder diameter	123 mm
Lifting / lowering time	app. 30 Sec.
Foundation depth	2,400 mm
Pump unit	3.0 kW
Ecological hydraulic fluid	12 l
Voltage	230/400 V - 50 Hz - 16 A

Arm superstructure	
Lifting pad included in the delivery	11028 (135 - 195 mm)
Min. height	135 - 195 mm
Arm length, min. - max.	665 - 1,055 mm

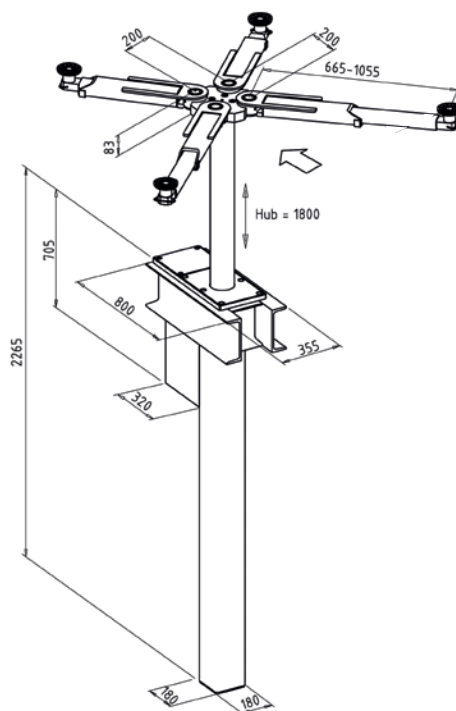
autop Maschinenbau GmbH

Sandkampstraße 90
 48432 Rheine | Germany
 ☎ +49 5971 8602-02
 ☎ +49 5971 8602-25
 ✉ info@autopstenhoj.com

STENHOJ A/S

Barrit Langgade 188-190
 7150 Barrit | Denmark
 ☎ +45 76821-330
 ☎ +45 76821-331
 ✉ info@autopstenhoj.com

Versions:
Steel cassette:

- Zinc-coated
- Coated

Installation:

- Superstructure on floor
- Ceiling installation
- Hydraulic pump unit in floor
- Hydraulic pump unit on wall

Optional extras:

- Large program of extra pads

**Special colours available
 on request!**

