

Masterlift 2.35 Pv

Electro-hydraulic twin-ram lift, 3.5 t, superstructure with flat lifting supports

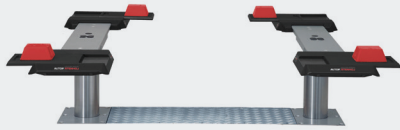

Application

- Check-in
- Wash
- Repairs and maintenance
- Test

Approvals / recommendations

- Renault
- ML 2.35 Pv 140-200:
Opel
- ML 2.35 Pv 160-220 xy:
Mercedes-Benz,
Volkswagen Group
- ML 2.35 Pv 170-240:
BMW / Mini
- ML 2.35 Pv 160-220
Premium:
Volvo

Description:

Steel cassette:

- Waterproof steel cassette

Hydraulic unit:

- Hard-chrome plated cylinder
- Flexible synchronization and safety system
- Corrosion-free guiding elements
- Pump unit with immersed motor
- Hydraulic oil
- Pneumatic emergency lowering
- Programmable pushbutton control unit

Superstructure:

- Stable lifting supports, lengthwise adjustable
- Rubber-coated, non-skid pads
- Low minimum height

Standard colours:

- Pv Standard: zinc coated
- Pv Premium: zinc coated and painted
RAL 9006 – white aluminum

Versions:

Steel cassette:

- Zinc-coated
- Coated
- Self-carrying

Superstructure:

- Lifting supports in different lengths (120-180, 140-200, 160-220 & 170-240)

Installation:

- Superstructure on floor
- Superstructure in floor
- Ceiling installation

Optional extras:

- XY-pads
- Sets of rubber blocks,
40, 60, 80 and 100 mm
- Traverse

Zinc coating and special colours on request!



Scan the QR-Code for detailed product information.

Further Information on www.autopstenhoj.com

autop Maschinenbau GmbH

Sandkampstraße 90
D-48432 Rheine

☎ +49 5971 8602-02

📠 +49 5971 8602-25

✉ info@autopstenhoj.com

STENHØJ A/S

Barrit Langgade 188-190
DK-7150 Barrit

☎ +45 76 82 13 30

📠 +45 76 82 13 31

✉ info@autopstenhoj.com

Technical data	
Lifting capacity	3,500 kg
Lifting height	1,950 mm
Working height	2,015 mm + rubber pads
Cylinder diameter	2 x 123 mm
Distance between cylinders	1,335 mm
Lifting / lowering time (high pressure)	approx. 30 sec.
Foundation depth	2,625 mm
Pump unit	3 kW
Hydraulic oil	10 l
Voltage	230 / 400 V – 50 Hz – 16 A

Pv superstructure	
Total width min. – max.	120 – 180: approx. 1,200 – 1,800 mm 140 – 200: approx. 1,400 – 2,000 mm 160 – 220: approx. 1,600 – 2,200 mm 170 – 240: approx. 1,700 – 2,400 mm
Min. height	65 mm

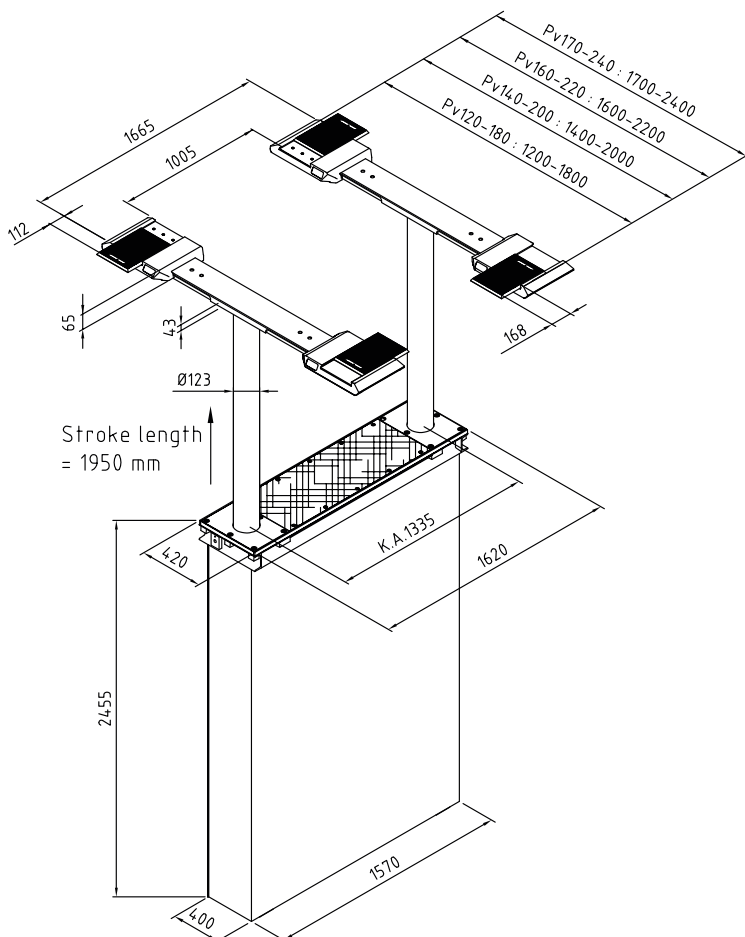

XY-pads with rubber



Various pads

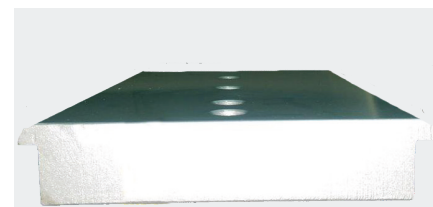

Solid lifting supports, zinc coated and painted